

CAPACITY	SYMBOL/SERIAL NO.	CIRCUIT DIAGRAM
AC100-240V, 50/60Hz		
28W		

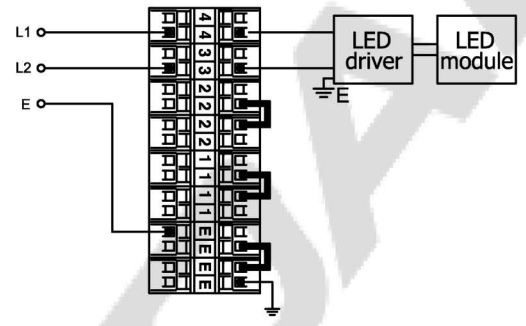

CIRCUIT DIAGRAM

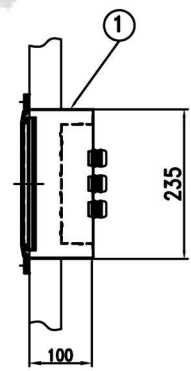
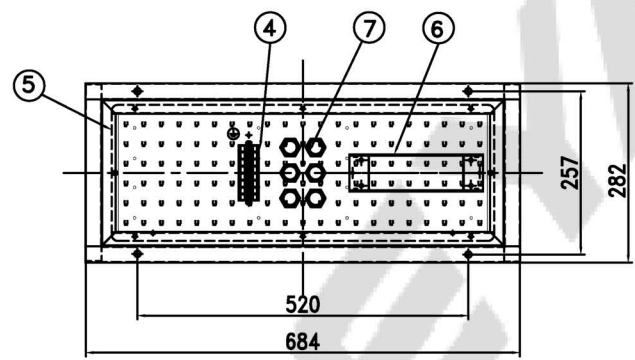
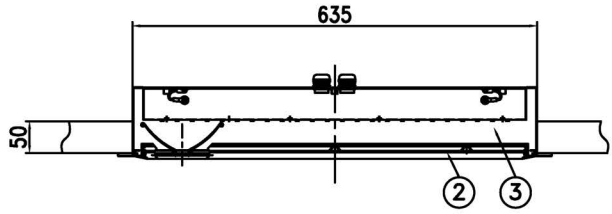
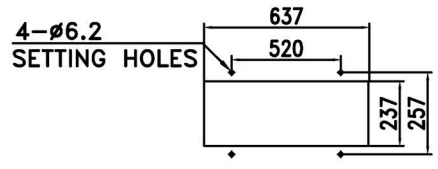

CUTTING DIMENSION

					4	TERMINAL BLOCK	-	1	CLAMPING 8P
7	CABLE GLAND(R25M)	BRASS	6	ø9~ø17	3	LED module	-	1	3,000±300K
6	LED driver	-	1		2	GLOBE	ACRYL	1	RED
5	LED module BRACKET	STEEL	1		1	BODY	STEEL	1	
NO	NAME OF PARTS	MATERIAL	Q'TY	REMARKS	NO	NAME OF PARTS	MATERIAL	Q'TY	REMARKS

APPROVED	J. W. PARK	UNIT	MM
CHECKED	S. M. SON	SCALE	N/S
DRAWING	B. K. HWANG	COLOR	N-9.3
DATE	2022.01.18	IP	44

TITLE;  
**NO-GAP LED CEILING LIGHT**  
 FOR MARINE USE

	MODEL NO.	LEB128WF-0550SNQRC30-A(R25M)	WEIGHT	6.8 Kg
	DWG NO.	LO1150230	SHEET NO.	17